

- KEYNOTES - SITE PLAN**
- 1 PROPOSED SIDEWALK
 - 2 PROPOSED 6" CURB
 - 3 PROPOSED 6" CURB AND GUTTER
 - 4 PROPOSED RIBBON GUTTER
 - 5 ENHANCED PAVING PER LANDSCAPE ARCHITECT PLAN
 - 6 PROPOSED TRASH ENCLOSURE
 - 7 TRAFFIC ARROW STRIPING
 - 8 PROPOSED LIGHT FIXTURE
 - 9 PROPOSED RFP RFP
 - 10 PROPOSED FIRE HYDRANT
 - 11 PROPOSED BIOPERILATION BASIN
 - 12 EXISTING FIRE HYDRANT
 - 13 EXISTING CURB AND GUTTER TO REMAIN
 - 14 PROPOSED MODULAR WETLAND SYSTEM
 - 15 PROPOSED UNDERGROUND DETENTION SYSTEM
 - 16 EXISTING CURB AND GUTTER TO BE REMOVED

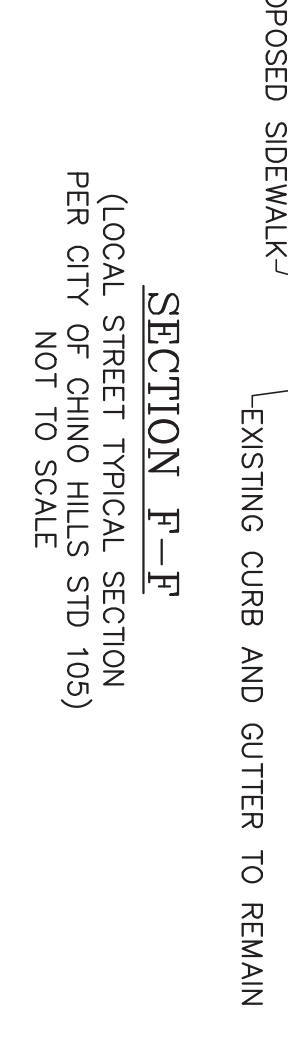

- STRUCTURAL SOURCE CONTROL BMPs**
- S-1 PROVIDE STORM DRAIN SYSTEM STENOUGHING AND SIGNAGE (CASQA NEW DEVELOPMENT BMP HANDBOOK SD-13)
 - S-2 DESIGN AND CONSTRUCT TRASH AND WASTE STORAGE AREAS TO REDUCE POLLUTION INTRODUCTION (CASQA NEW DEVELOPMENT BMP HANDBOOK SD-32)
 - S-3 USE EFFICIENT IRRIGATION SYSTEMS & LANDSCAPE DESIGN, WATER CONSERVATION, ORDNANCE: CASQA NEW DEVELOPMENT BMP HANDBOOK SD-12)
 - S-4 TOP-OF-CURB, SIDEWALK, OR PAVEMENT
 - S-5 PROTECT SLOPES AND CHANNELS AND PROVIDE ENERGY DISSIPATION (CASQA NEW DEVELOPMENT BMP HANDBOOK SD-12)
 - S-6 WASH WATER CONTROL FOR FOOD PREPARATION AREAS

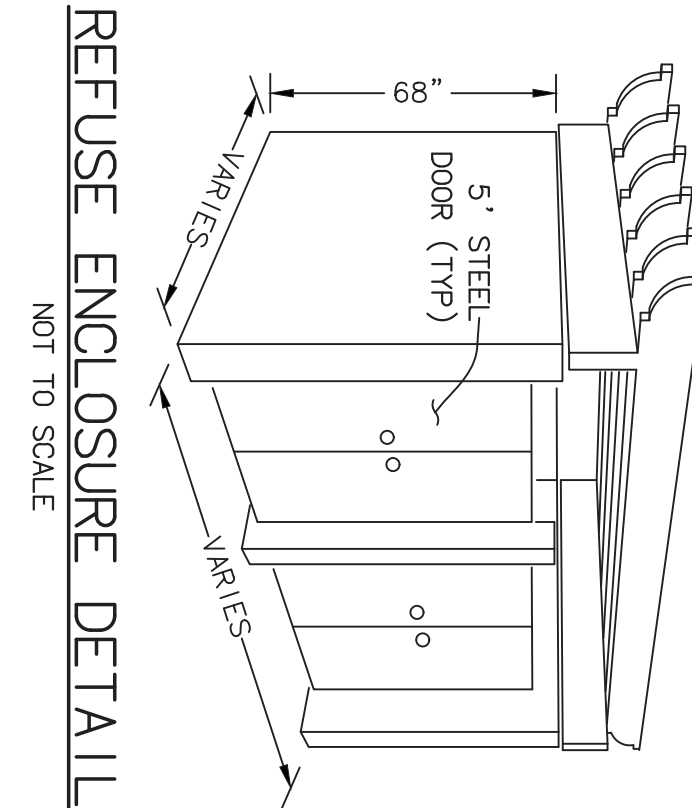

- NON-STRUCTURAL SOURCE CONTROL BMPs**
- N-1 EDUCATION OF PROPERTY OWNERS, TENANTS AND OCCUPANTS ON STORMWATER BMPs
 - N-2 ACTIVITY RESTRICTIONS
 - N-3 LANDSCAPE MANAGEMENT BMPs
 - N-4 BMP MAINTENANCE
 - N-5 TITLE 22 COR COMPLIANCE (COURTLY)
 - N-6 LOCAL WATER QUALITY ORDNANCES
 - N-7 SPILL CONTINGENCY PLAN
 - N-8 UNIFORM FIRE CODE IMPLEMENTATION
 - N-9 LITTER/DEBRIS CONTROL PROGRAM
 - N-10 EMPLOYEE TRAINING
 - N-11 HOUSEKEEPING OF LOADING DOCKS
 - N-12 CATCH BASIN INSPECTION PROGRAM
 - N-13 VACUUM SWEEPING OF PRIVATE STREETS AND PARKING LOTS
 - N-14 COMPLY WITH ALL OTHER APPLICABLE NPDES PERMITS

PARKING STALL NOTE:
ALL PARKING STALLS THAT ARE LESS THAN 19' LONG MUST HAVE AN OVERHANG.

BIORETENTION BASIN NOTE:
BIORETENTION WITH UNDERDRAIN BMP SERVES AS PRE VS POST MITIGATION & FIRST FLUSH BASIN.

MA MacDavid Aubot
and Associates Incorporated

REC Consultants, Inc.

HOWARD T.L. 2681
Associates

BIZPARK CHINO HILLS

CONCEPTUAL SITE PLAN

CHINO HILLS, CA

H.G. Fenton Company

Architecture • Planning • Interiors
14 HUGHES SUITE 804
IRVINE, CA 92618
(949) 265-2200

Civil Engineering • Environmental
Land Surveying
2442 Second Avenue, San Diego, CA 92101
(619) 232-9200 (619) 232-9210 Fax

Landscape Architecture
2442 Second Avenue,
San Diego, CA 92108
(619) 232-9200 (619) 232-9210 Fax