

# CITY OF CHINO HILLS TENTATIVE PARCEL MAP NO. 20106

BEING A SUBDIVISION OF LOT 3 AND 4 OF BLOCK 43 OF TRACT NO. 2650, IN THE CITY OF CHINO HILLS,  
COUNTY OF SAN BERNARDINO, STATE OF CALIFORNIA AS PER MAP RECORDED IN BOOK 37 PAGES 69-72, IN  
THE OFFICE OF THE COUNTY RECORDER SAID COUNTY .

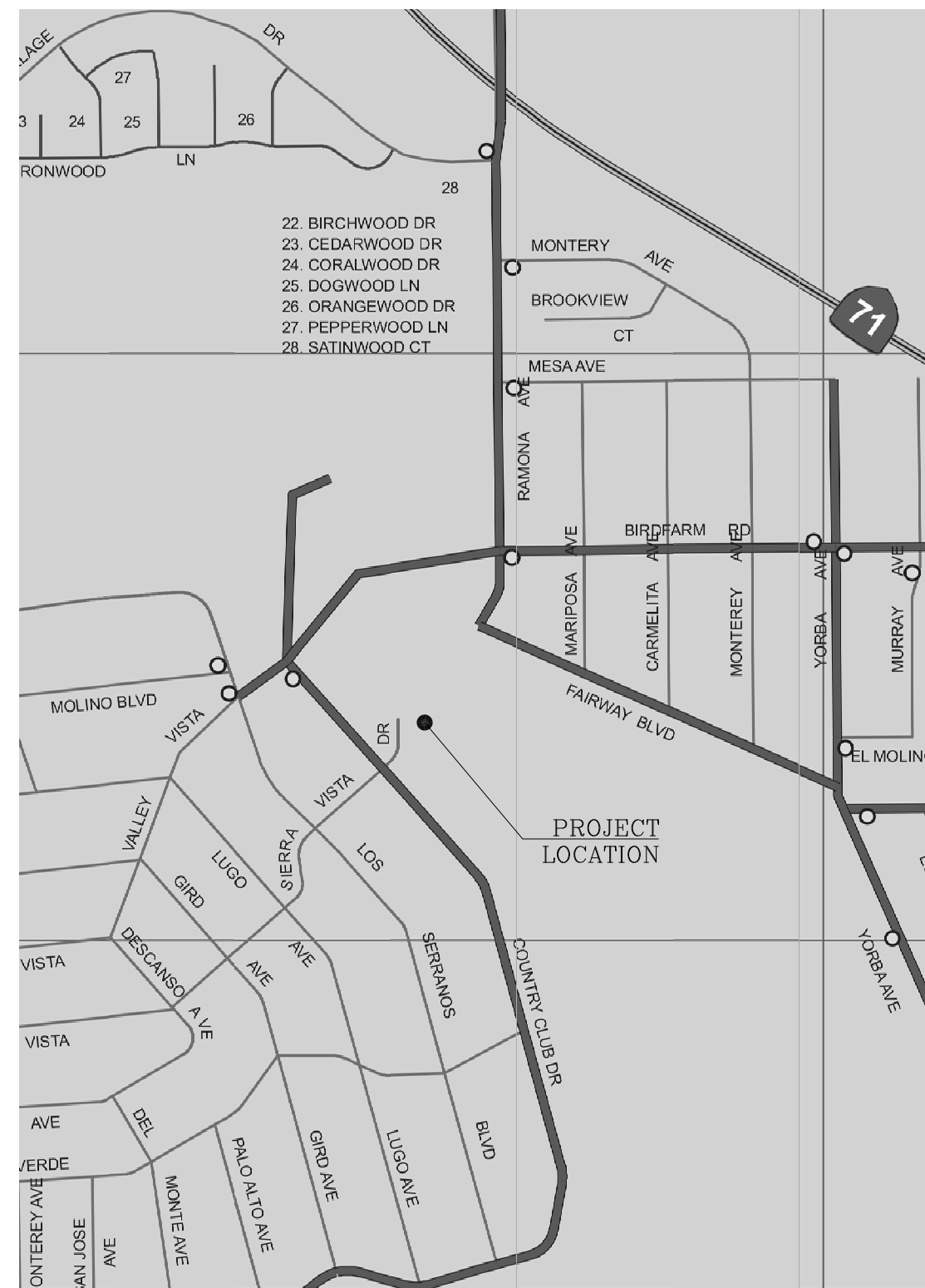

VICINITY MAP

APN: 1028-083-17-0000



SIERRA VISTA DR.

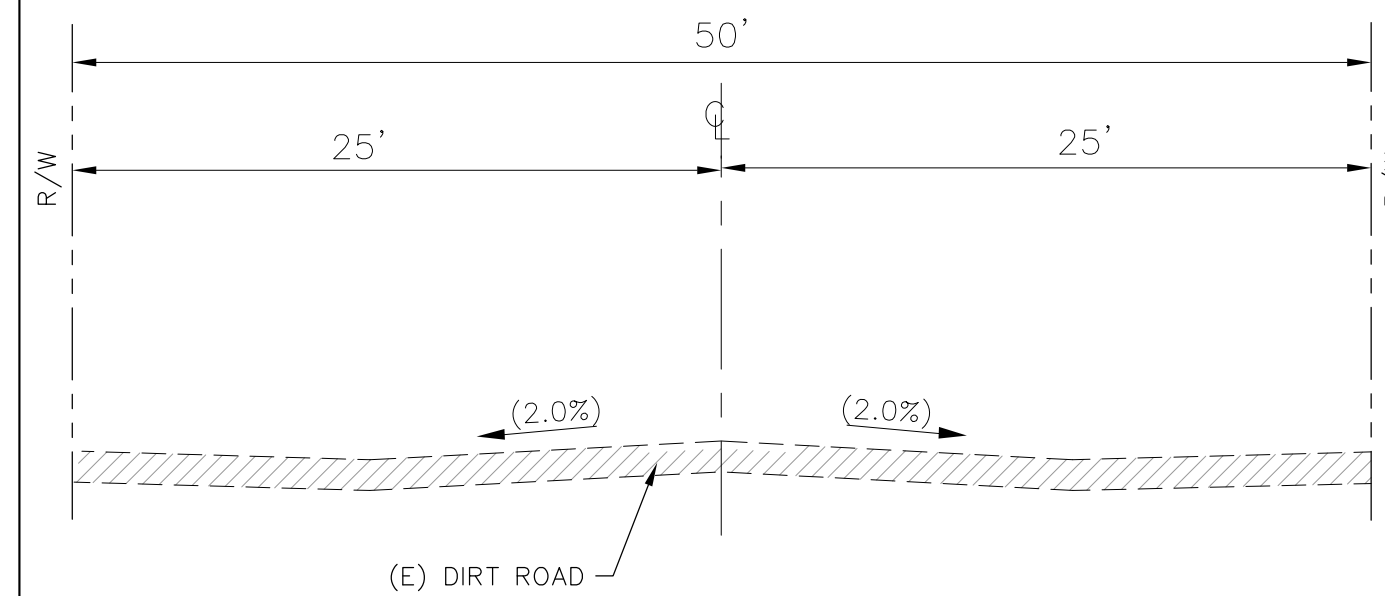

TYPICAL RIGHT OF WAY  
NOT TO SCALE

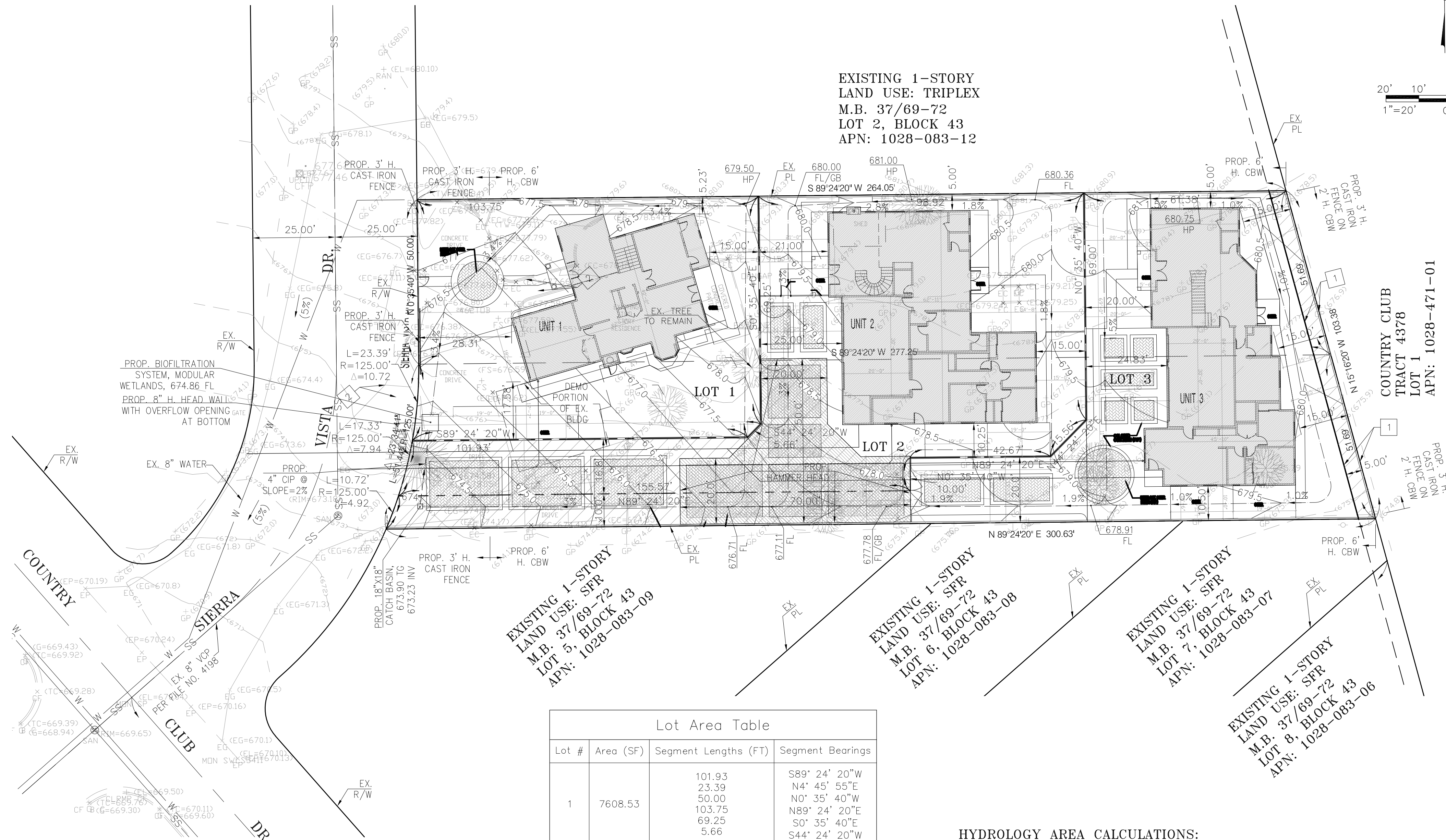

EXISTING 1-STORY  
LAND USE: TRIPLEX  
M.B. 37/69-72  
LOT 2, BLOCK 43  
APN: 1028-083-12

EXISTING 1-STORY  
LAND USE: SFR  
M.B. 37/69-72  
LOT 3, BLOCK 43  
APN: 1028-083-09

EXISTING 1-STORY  
LAND USE: SFR  
M.B. 37/69-72  
LOT 6, BLOCK 43  
APN: 1028-083-08

EXISTING 1-STORY  
LAND USE: SFR  
M.B. 37/69-72  
LOT 7, BLOCK 43  
APN: 1028-083-07

EXISTING 1-STORY  
LAND USE: SFR  
M.B. 37/69-72  
LOT 8, BLOCK 43  
APN: 1028-083-06

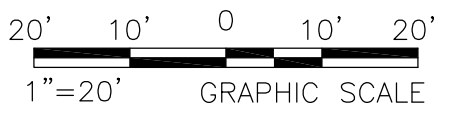

20' 10' 0' 10' 20'  
1"=20' GRAPHIC SCALE

### ABBREVIATIONS:

- APN ASSESSOR'S PARCEL NUMBER
- BLDG BUILDING
- CBW CONCRETE BLOCK WALL
- C/L, CL CENTERLINE
- CIP CAST IRON PIPE
- CF CURB FACE
- CLF CHAIN LINK FENCE
- CONC CONCRETE
- EG EDGE OF CONCRETE
- EP EDGE OF PAVEMENT
- EL ELEVATION
- FS FINISHED SURFACE ELEVATION
- EXIST/EX EXISTING
- EG EXISTING GRADE
- FG FINISH GRADE
- FL FLOW LINE ELEVATION
- GB GRADE BREAK
- H HIGH
- HP HIGHEST POINT
- INV INVERT ELEVATION
- NTS NOT TO SCALE
- NO NUMBER
- PM PARCEL MAP
- PROP PROPOSED
- PVMT PAVEMENT
- PVC POLYVINYL CHLORIDE
- P/L PROPERTY LINE
- R/W RIGHT OF WAY
- SFR SINGLE FAMILY RESIDENTIAL
- STD STANDARD
- TC TOP OF CURB ELEVATION
- VCP VERIFIED CLAY PIPE
- W.I.F. WROUGHT IRON FENCE

### LEGEND:

- PROPERTY LINE
- CENTERLINE
- TREE
- EX. SEWER LINE
- FIRE HYDRANT
- SMH
- POWER POLE
- EXISTING ELEVATION
- PROPOSED ELEVATION
- EXISTING BUILDING
- EASEMENT
- FLOW LINE/SHEET FLOW
- PROPOSED BUILDING

LOT #	LOT SIZE (SF)	LOT WIDTH (FT)	LOT DEPTH (FT)
1	7608.53	103.88	102.84
2	10120.99	84.78	98.92
3	10156.03	101.58	74.48

### UTILITY IN THE CITY OF CHINO HILLS

- SEWER AND WATER: CITY OF CHINO HILLS UTILITIES DIVISION (909) 364-2660
- GAS COMPANY: SOUTHERN CALIFORNIA GAS COMPANY (800) 427-2200
- ELECTRIC COMPANY: SOUTHERN CALIFORNIA EDISON (800) 655-4555
- CABLE COMPANY: TIME WARNER CABLE (800) 892-2253
- TRASH COMPANY: REPUBLIC SERVICES (800) 238-2444
- TELEPHONE COMPANY: FRONTIER COMMUNICATIONS (877) 372-8783

Lot Area Table			
Lot #	Area (SF)	Segment Lengths (FT)	Segment Bearings
1	7608.53	101.93	S89° 24' 20"W
		23.39	N4° 45' 55"E
		50.00	N0° 35' 40"W
		103.75	N89° 24' 20"E
		69.25	S0° 35' 40"E
		5.66	S44° 24' 20"W
2	10120.99	69.00	S0° 35' 40"E
		15.56	S44° 24' 20"W
		42.67	S89° 24' 20"W
		10.00	S0° 35' 40"E
		155.57	S89° 24' 20"W
		17.33	N14° 05' 48"E
3	10156.03	300.68	S89° 24' 20"W
		10.72	N20° 31' 34"E
		155.57	N89° 24' 20"E
		10.00	N0° 35' 40"W
		42.67	N89° 24' 20"E
		15.56	N44° 24' 20"E

### HYDROLOGY AREA CALCULATIONS:

	PERVIOUS AREA (SF/AC, %)	IMPERVIOUS AREA (SF/AC, %)	TOTAL AREA(SF/AC, %)
EXISTING	24,245/0.56, 87%	3,640/0.08, 13%	27,885/0.64, 100%
PROPOSE	9,618/0.22, 35%	18,268/0.42, 65%	

### LID BMPs:

- PROPOSE STORMWATER BIOFILTRATION SYSTEM DETAIL PER MODULAR WETLANDS, MODEL # MWS-L-4-4-C.
- PLACE "NO DUMPING" SIGN AT THE BMPs;

### CIVIL ENGINEER

GUOXIN MIAO  
APPLE ENGINEERING GROUP  
9080 TELSTAR AVE., SUITE 309  
EL MONTE, CA 91731  
TEL: 626-552-9818

Underground Service Alert  
Call: TOLL FREE 811  
www.call811.com  
TWO WORKING DAYS BEFORE YOU DIG

REVISIONS	
MARK	DATE

Plan Prepared By:	
GUOXIN MIAO	10/5/2020 DATE
SCALE: 1"=20'	DATE: 10/5/2020
DRAWN BY: YAV	CHECKED BY: GM

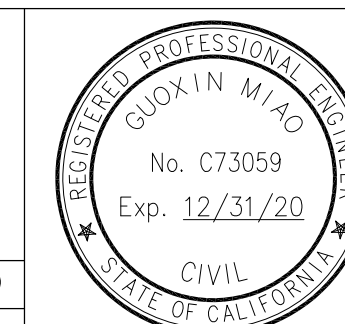

### LEGAL DESCRIPTION:

TRACT NO. 2650 LOTS 3 AND 4 BLK 43.

### PROJECT DESCRIPTION

- 3 LOT SUBDIVISION LOCATED AT 4443 SIERRA VISTA AVE CHINO HILLS, CA 91709 APN: 1028-083-17
- EXIST. ZONING: R-S (LOW DENSITY RESIDENTIAL)
- PROP. ZONING: R-S (LOW DENSITY RESIDENTIAL)
- LOT SIZE: 27885.56 SF / 0.640 ACRES
- EARTH WORK: CUT: 0 CF; FILL: 100 CF;
- IMPERMEABLE AREA: 18258.56 SF, 65% PERMEABLE AREA: 9,627 SF, 35%

### NOTES

- REMOVE ALL TREES WITHIN PROJECT SITE UNLESS OTHERWISE NOTED.

### EASEMENTS

- EXISTING 5' EASEMENT FOR PUBLIC UTILITIES PURPOSES.
- EXISTING 5' EASEMENT FOR PIPE PURPOSES.

TENTATIVE PARCEL MAP NO. 20106  
SIERRA VISTA, CHINO HILLS

OWNER: GREENPLANET HOME TECHNOLOGY LLC  
ADDRESS: 13348 WOODEN GATE WAY, CORONA, CA 92880  
PHONE: (909) 341-7777

A.P.N. 1028-083-17

SHEET 1 OF 1 SHEETS