

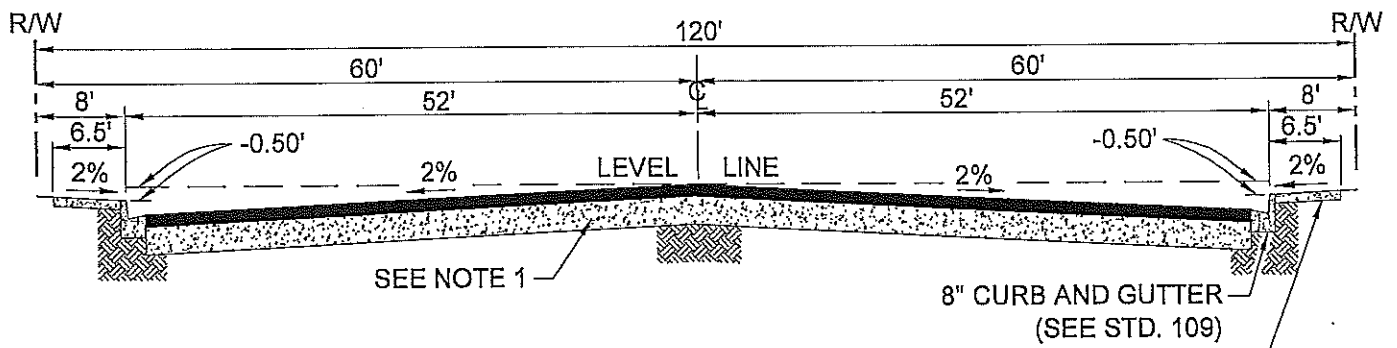

**TYPICAL SECTION  
WITH RAISED MEDIAN**



**TYPICAL SECTION  
WITH PAINTED MEDIAN**

**NOTES:**

1. STRUCTURAL SECTION OF ROADWAY SHALL BE DETERMINED FROM SOILS REPORT, TRAFFIC INDEX, AND STREET DESIGNATION, PREPARED BY SOILS ENGINEER PRIOR TO FINAL APPROVAL OF IMPROVEMENT PLANS. MINIMUM STRUCTURAL SECTION PER CITY STANDARD 90 SHALL PREVAIL.
2. DRAINAGE FACILITIES SHALL BE PROVIDED TO DEWATER RAISED MEDIAN AREAS.
3. IRRIGATION SYSTEM IN MEDIAN AREA SHALL BE DRIP OR BUBBLE SYSTEM.
4. CURB RETURNS AT MAJOR ARTERIALS SHALL HAVE A RADIUS EQUAL TO 35 FEET UNLESS OTHERWISE APPROVED BY THE CITY ENGINEER.
5. AC OVERLAY AND FINISH COURSES SHALL BE 0.1-FT. MINIMUM IN THICKNESS, D2-PG 64-10 OR D2-PG 64-10 RAP. BASE COURSES SHALL BE MINIMUM 0.15', C2-PG 64-10 OR C2-PG 64-10 RAP UNLESS OTHERWISE APPROVED BY THE CITY ENGINEER.

APPR. BY:		07/11
	STEVEN C. NIX, CITY ENGINEER	DATE
DATE	REVISION	BY

**CITY OF CHINO HILLS  
ENGINEERING DEPARTMENT**

**6 LANE-MAJOR ARTERIAL**

**100**